

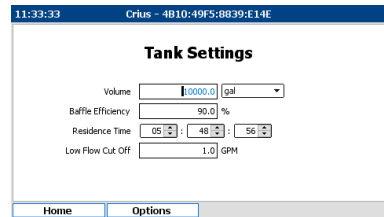

DAFSense Coagulation Controller

DAFSense is a low cost, highly effective integrated coagulation controller that accepts multiple inputs and calculates, with modified PID controls, the optimum coagulant and flocculant dose for a Dissolved Air Flotation (DAF) solids and fats, oils and grease (FOG) removal system.

- **Configured and optimised for each site**
- **Stable and reliable – excellent process control**
- **Reduced solids and reduced chemical usage**
- **Low cost – integrated system (no industrial PC required)**



"If you want to control something reliably and robustly then you need to measure and allow for all the key affecting variables."

Dr. Craig Stracey, Pi

At a fraction of the cost of competitor's solutions the DAFSense uses a highly advanced instrument controller to do all the reporting and all the calculations required, thereby removing the need for individual measurement analysers and PLCs or industrial PCs. This reduction in complexity allows for massive cost savings (>50%) on alternative systems without sacrificing performance.

CRIUS® 4.0 DAFSense



- **High Quality - Lowest Cost**
- **Multilingual**
- **High resolution colour display**
- **Intuitive user interface**
- **Downloadable data logs**
- **Customisable home pages**
- **Up to 4 sensors**
- **Remote access via LAN/3G/4G**
- **Expandable to 16 sensors**
- **8 digital I/O**
- **Optional Modbus/ Profibus comms**

Sensors for DAF Coagulation Control



pH - self cleaning
Combines with a feedback PID control to effectively control the pH



Self cleaning Suspended Solids—inlet and outlet

One installed in the inlet stream combining with the plant flow signal to give feed forward control.

A second installed in the plant effluent combining with a feedback PID control to modify the feed forward control to give the desired plant outcomes.

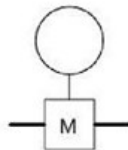

Flow - signal from existing plant flow meter

Key Features

- **Self Cleaning - All sensors keep themselves clean**
- **PLC Integration - Modbus or profibus integration**
- **Inline Fittings - Easily removable for maintenance**
- **pH - Control options - A complete package**
- **Pipe Insertion - Simple installation**



For more information please see the individual brochure for CRIUS® 4.0

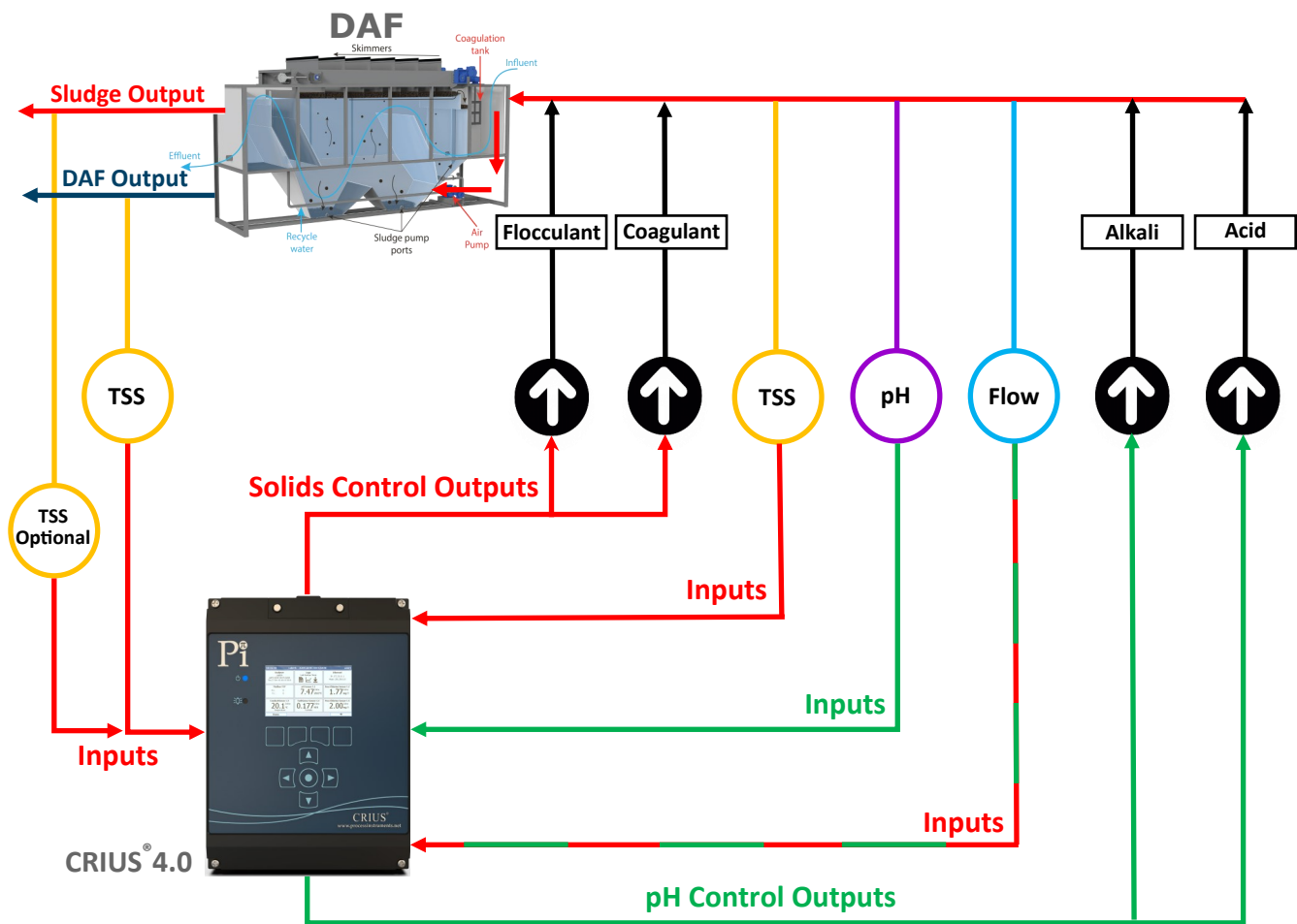

Fig.1 - DAF System

KEY

Green—pH measurement and control

Red—TSS measurement and control

Philosophy

To effectively control coagulant and flocculant dose to a DAF it is important in order to measure four main parameters;

- pH
- Influent Solids
- Effluent Solids
- Flow

With these parameters all feeding into a single controller, and with the input of desired outputs by an operator, e.g. the solids setpoint for the effluent, the DAFSense can use the parameters above to provide an output to a dosing pump to ensure that the correct amount of coagulant is added at the front of the process to give the desired reduction in solids.

Effectively, the DAFSense uses “flow proportional feed forward control with residual trim” to an effluent solids setpoint. What this means is that using experience the operator inputs the “normal” coagulant pump outputs for a “normal” solids input at a “normal” flow rate (you can substitute the word nominal for the word normal).

Then as the flow changes or influent solids change, the dosing output changes proportionally with the final effluent solids varying the amount of change to hit a solids output target.

Protections

In order to ensure robustness the DAFSense comes with many protections included:

- Max dosage
- Overfeed protection
- Default to manual settings on alarm
- Email/ text alarms
- Remote Access via LAN or GPRS modem
- Integration with plant SCADA
- Manual control overrides

Installation Outcomes

- Lower energy usage
- Reduced chemical usage
- Improved consent compliance
- Online reports for compliance reports

Consultation

As each DAFSense is configured to effectively manage coagulation and pH control on specific plants, please contact Pi or your local sales outlet to arrange a site survey.